

## ProSet 1600 Rivet Tool

### Hydropneumatic

The ProSet® 1600 is among the highest force-to-weight ratio blind riveting tools in the industry. In addition to its compact design, the comfortable, small rounded grip reduces user fatigue and increases ability to manoeuvre in tight spaces.

The ProSet® 1600 will keep your production lines running at full speed. Thanks to the innovative quick disconnect nose housing, the front end components can be serviced in minutes – without tools. With the 1600 Mandrel Collection System (MCS) model, spent mandrels are instantly collected, and with the quick disconnect system, disposal takes no time, keeping work areas safe and clean with minimal downtime.

This ProSet® 1600 model also features an innovative left or right, On/Off swivel air fitting providing additional flexibility, conserving energy and reducing operating costs.



**Requires no tools for routine maintenance and cleaning. Front end component can be serviced in minutes, without tools and without removing the tool from the production line.**

### Placing Capability

2.0 mm micro rivets, 2.4mm and 3.2mm diameter rivets in all materials and up to 4.0mm all steel open end rivets.

### Technical Data

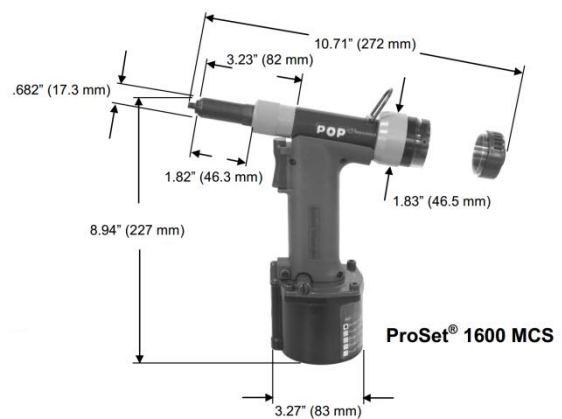
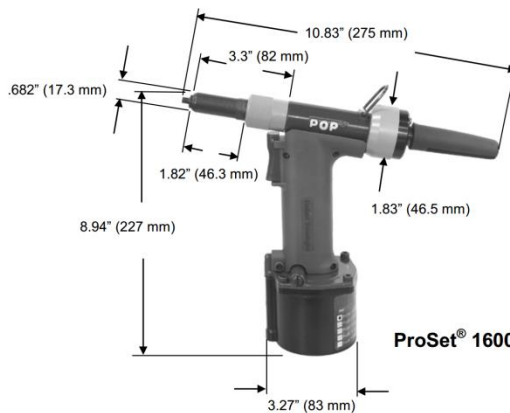

<b>Weight</b>	:	0.97 kg
<b>Tool Stroke</b>	:	18 mm
<b>Working Pressure</b>	:	5.0 - 6.9 bar
<b>Pulling Force</b>	:	4,850 N at 6.2 bar
<b>Force / Weight Ratio</b>	:	5 kN/kg
<b>Air Consumption</b>	:	1.22 litres / rivet

	:	1.04 kg
	:	18 mm
	:	5.0 - 6.9 bar
	:	4,850 N at 6.2 bar
	:	4.6 kN/kg
	:	70 litres / min (max)

### Performance

- High force-to-weight ratio
- Quick disconnect nose housing, jaw case, and mandrel collector

### Ergonomic

- Lightweight polymer construction
- Comfortable two finger, low activation force trigger
- Directionable air exhaust

### Economy

- Conserve energy, On/Off, left or right swivel air fitting

For accessories options, contact Gripwell Sales for assistance